

ARCHITECTURAL DETAILS

ENLARGED DRAWINGS OF SPECIFIC ASSEMBLIES

USED TO DESIGN AND SOLVE CONSTRUCTION ASSEMBLIES

START FREEHAND IN THE DESIGN STAGES OF A PROJECT AND EVOLVE INTO HARD-LINE DETAILS AS THEY AID IN THE DESIGN PROCESS.

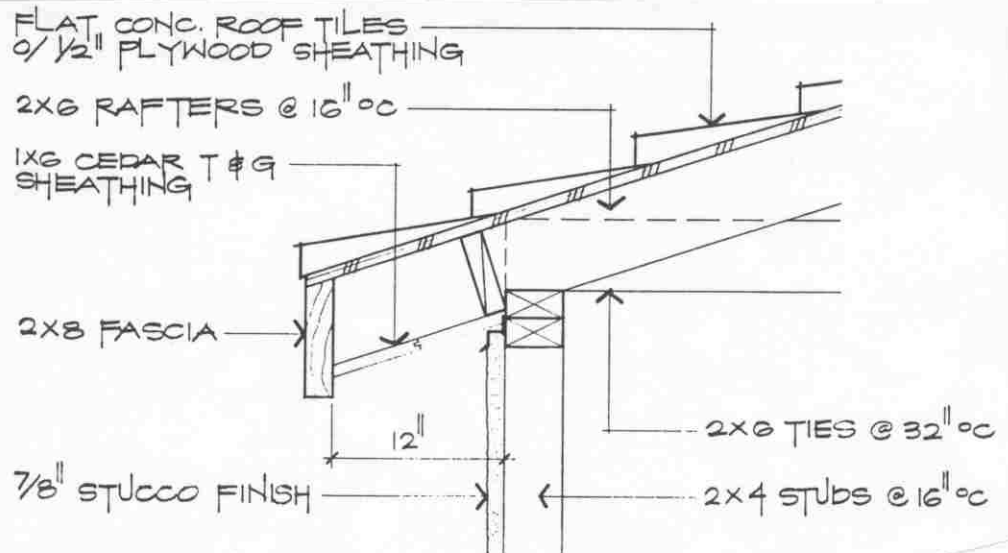

EAVE DETAIL

SCALE: 1/2" = 1'-0"

DETAIL TYPES

DETAILS CAN BE CLASSIFIED INTO 3 MAJOR CATEGORIES

FUNCTION

- CONTROLLING LEAKAGE (WATER, AIR, HEAT FLOW, WATER VAPOR, SOUND)
- ACCOMMODATING MOVEMENT (EXPANSION)
- PROVIDING STRUCTURAL SUPPORT.
- PASSAGES FOR MECHANICAL & ELECTRICAL UTILITIES.
- HEALTH & SAFETY (CODE REQUIREMENTS)

CONSTRUCTIBILITY

- EASE OF ASSEMBLY
- EFFICIENT USE OF MATERIALS

AESTHETICS

- ORNAMENTATION
- CONTRIBUTORY DETAILS
- TRANSITIONS

UNIVERSITY OF TOLEDO
ENGINEERING TECHNOLOGY DEPT.
ARCT-1100 ARCHITECT. GRAPHICS

**ARCHITECTURAL
DETAILS**

SEMESTER: _____

CLASS HANDOUT: _____

AD-1

DRAWING DETAILS - STEP BY STEP



STEP 1 - LIGHT LAYOUT OF BASIC FORMS

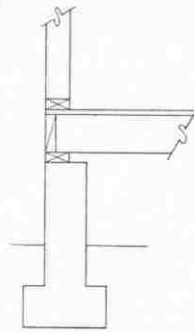

STEP 2 - ADDING RELATED INFORMATION

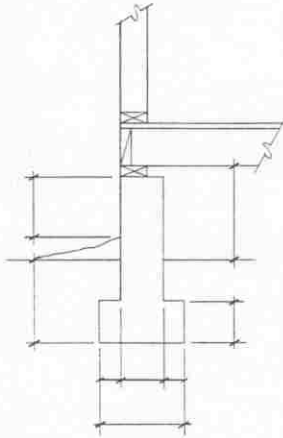

STEP 3 - DIMENSIONING

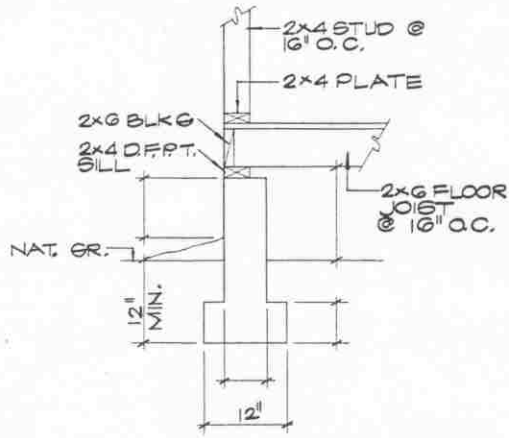

STEP 4 - ADDING NOTES

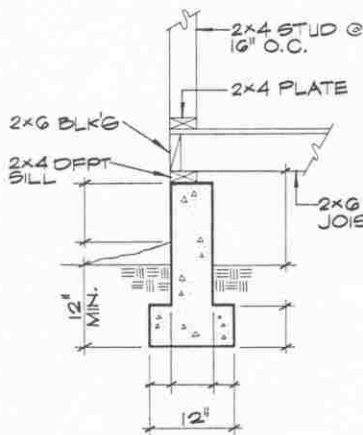

STEP 5 - PROFILING

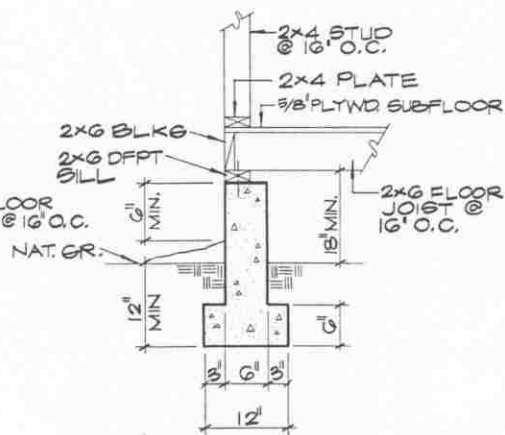

TYPICAL FOOTING DET. (A)
3/4" = 1'-0"
STEP 6 - REFERENCING

UNIVERSITY OF TOLEDO
ENGINEERING TECHNOLOGY DEPT.
ARCT-1100 ARCHITECT. GRAPHICS

DETAIL
PROCEDURES

SEMESTER: _____

CLASS HANDOUT: _____

AD-2

RULES OF DETAILING

- DRAW IT IN THE ORDER THAT IT'S BUILT.
- FOLLOW THE STEP BY STEP PROCEDURE.
- DON'T CROSS LEADERS.

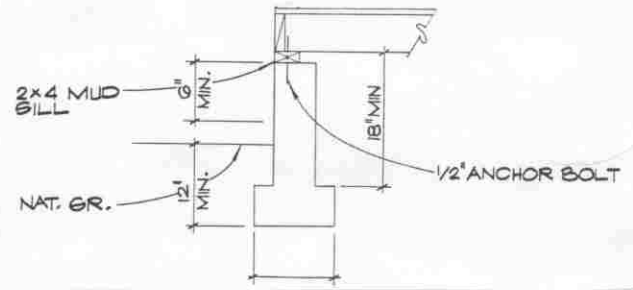

- DRAWING NOTES FORMAT: SIZE, NAME, SPACING AND FINAL INFO.

SIZE	NAME
1/2" x 10" LONG	ANCHOR BOLT EMBEDDED
7" INTO CONC.,	6'-0" O.C., 12" FROM CORNERS

- INSIDE OF BUILDING TO RIGHT, OUTSIDE TO THE LEFT.
- DRAW LUMBER TO ACTUAL DIMENSIONS NOT NOMINAL.
- VERTICALLY PLACED DIMENSIONS READ TO FROM THE RIGHT.

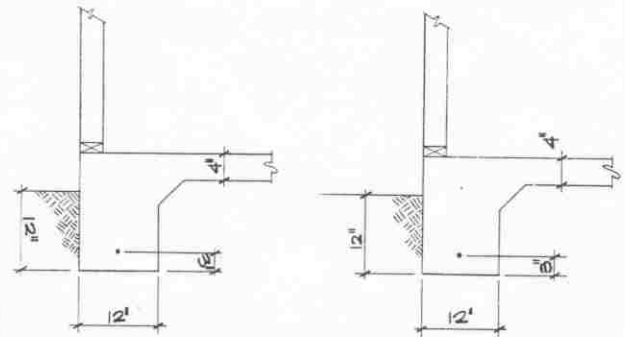

- USE EXTENSION LINES LIBERALLY.

INCORRECT

CORRECT

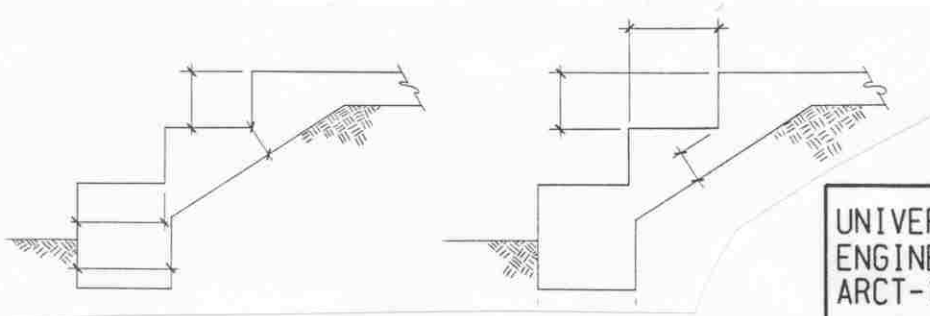

UNIVERSITY OF TOLEDO
ENGINEERING TECHNOLOGY DEPT.
ARCT-1100 ARCHITECT. GRAPHICS

*RULES OF
DETAILING*

SEMESTER: _____

CLASS HANDOUT: _____

AD-3

RULES OF DETAILING

- AVOID BRAND NAMES (UNLESS REQUIRED BY THE OWNER).
- DON'T SHARE NOTES BETWEEN DETAILS.
- DON'T USE SLANG OR FIELD EXPRESSIONS.
- USE STANDARD ABBREVIATIONS IF YOU MUST.
- USE STANDARD LUMBER SYMBOLS FOR BLOCKING, CONTINUOUS AND FINISHED TYPES OF WOOD.

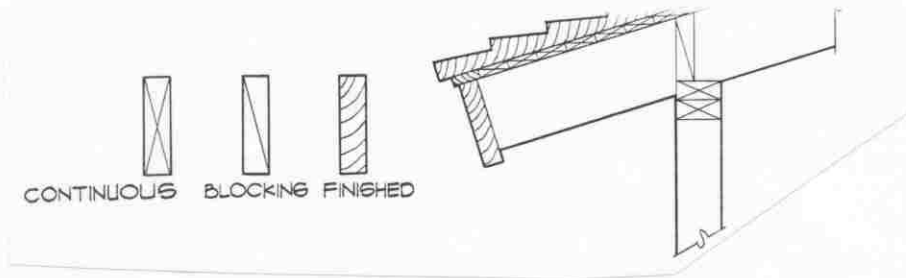

- USE BREAK LINES WHERE THE DETAIL IS DISCONTINUED.

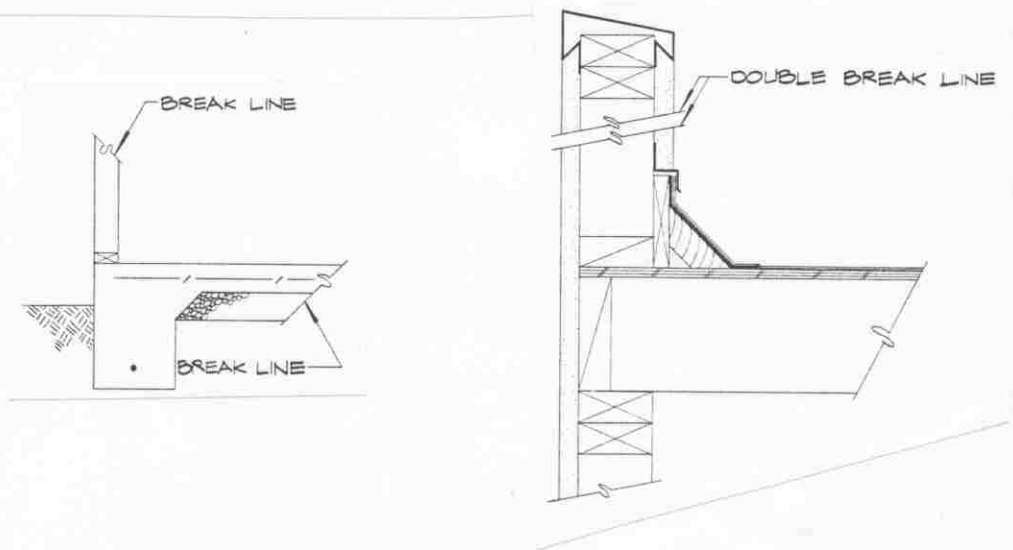

- PROFILE (DARKEN THE OUTLINE) OF THE MOST IMPORTANT PART OF THE DETAIL. USE STANDARD PATTERNS FOR EMPHASIS.

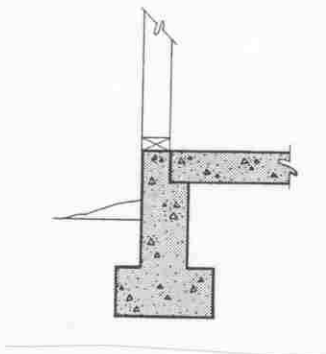

UNIVERSITY OF TOLEDO
ENGINEERING TECHNOLOGY DEPT.
ARCT-1100 ARCHITECT. GRAPHICS

RULES OF DETAILING

SEMESTER: _____

CLASS HANDOUT: _____

AD-4