

# SKETCHING

## INFORMAL GRAPHICAL PORTRAYAL OF OBJECTS OR ASSEMBLIES FOR:

- FIELD DRAWINGS
- EXPRESSING DESIGN INTENT
- CLARIFICATIONS
- RECORDING VERBAL EXPLANATIONS

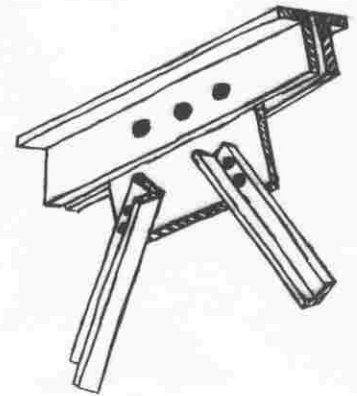
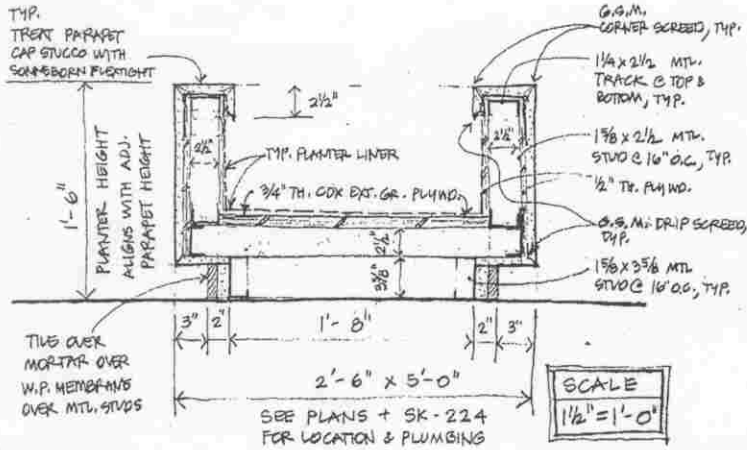
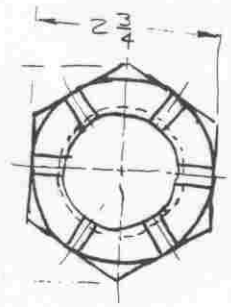

## VIEWS DEPEND ON WHAT YOU ARE ATTEMPTING TO DESCRIBE.

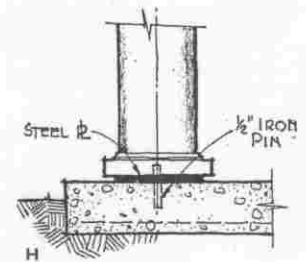
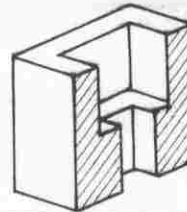
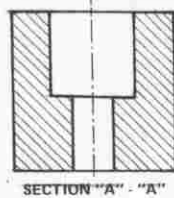
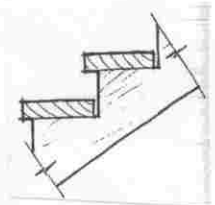
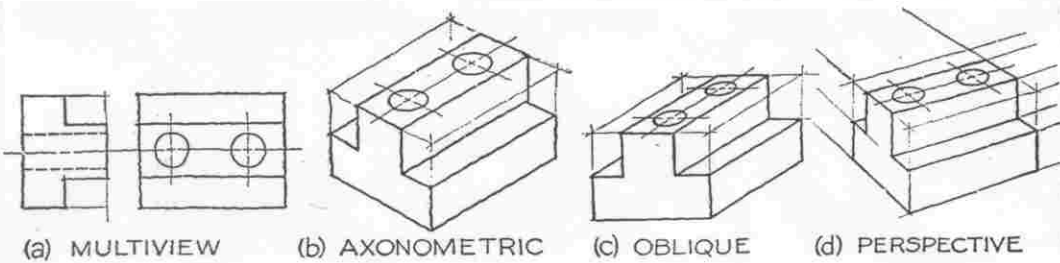

**SCALE: NOT IMPORTANT EXCEPT LARGE ENOUGH TO CONVEY IDEAS AND PROPORTIONAL IN ALL ELEMENTS.**

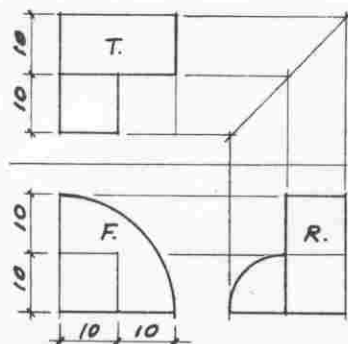
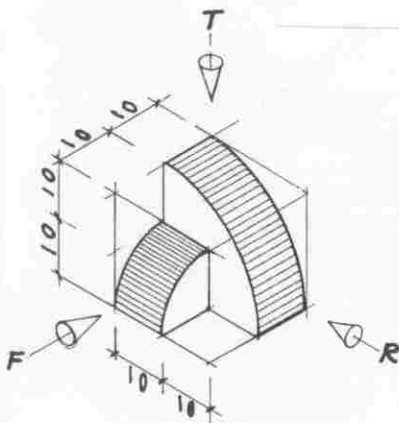

UNIVERSITY OF TOLEDO  
ENGINEERING TECHNOLOGY DEPT.  
CET-1100 ARCHITECT. GRAPHICS

**TECHNICAL  
SKETCHING**

SEMESTER: \_\_\_\_\_

CLASS HANDOUT: \_\_\_\_\_

**TS-1**

## STRAIGHT LINES

USE FREE AND EASY WRIST MOTION.  
DRAW LEFT TO RIGHT HORIZONTALLY.  
DRAW DOWNWARD VERTICALLY.  
INCLINED LINES CAN BE CONFORMED TO  
H OR V BY TILTING PAPER IN PROPER DIRECTION.

MECHANICAL LINE

FREEHAND LINE

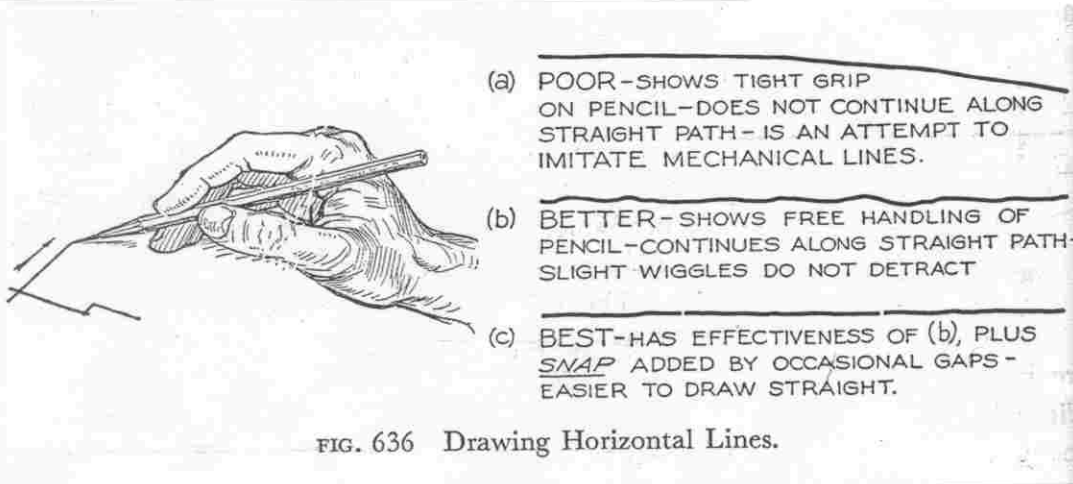

FIG. 636 Drawing Horizontal Lines.

PENCIL: MEDIUM SOFT GRADE FOR DARK LINES.  
GRIP: NOT TOO TIGHT TO ALLOW FOR FREEDOM, SNAP & CONFIDENCE.  
PAPER: TILTED TO AID IN SMOOTH FLOW OF LINE DIRECTIONS.

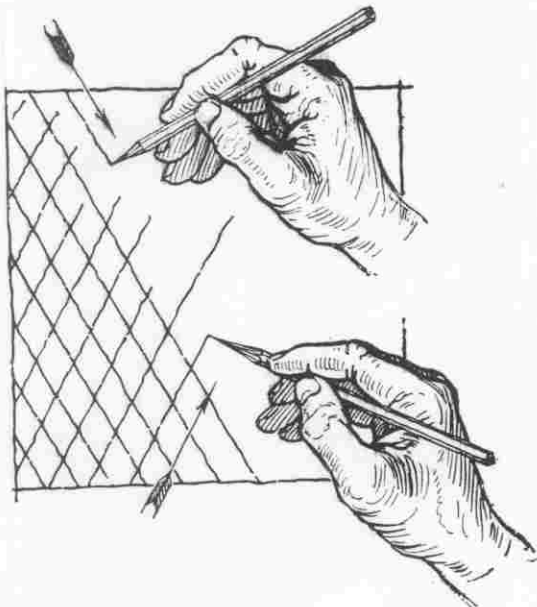

FIG. 638 Drawing Inclined Lines.

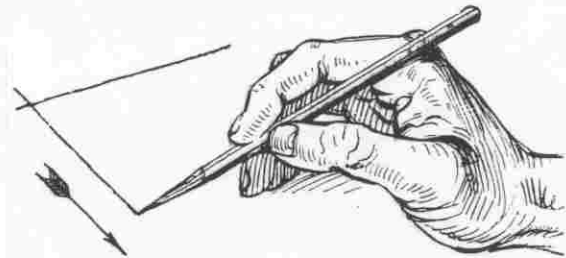

FIG. 637 Drawing Vertical Lines.

ROUGH IN LINES LIGHTLY.  
KEEP AIM ON ENDPOINT (USE SMALL DOT OR TICK)  
NO PAUSES, USE ONE CONTINUOUS STROKE.  
SLIGHT WIGGLES ARE FINE.

UNIVERSITY OF TOLEDO  
ENGINEERING TECHNOLOGY DEPT.  
CET-1100 ARCHITECT. GRAPHICS

TECHNICAL  
SKETCHING

SEMESTER: \_\_\_\_\_

CLASS HANDOUT: \_\_\_\_\_

TS-2

## CIRCLE-ARC SKETCHING METHODS

1. INSIDE A SQUARE
2. USING RADIAL LINES
3. HAND COMPASS FROM PAPER

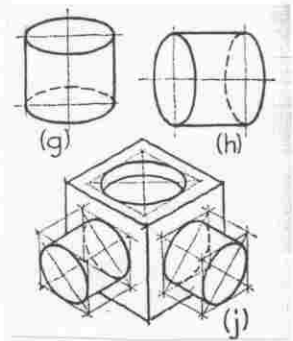
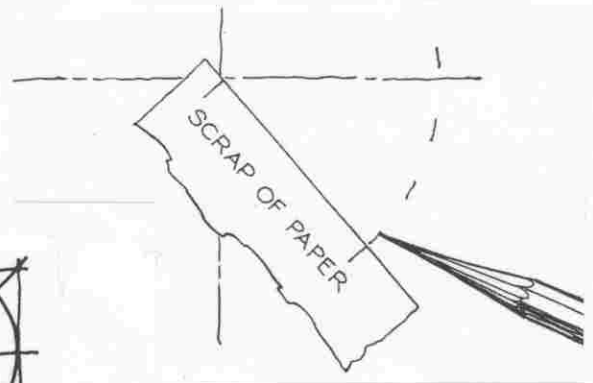
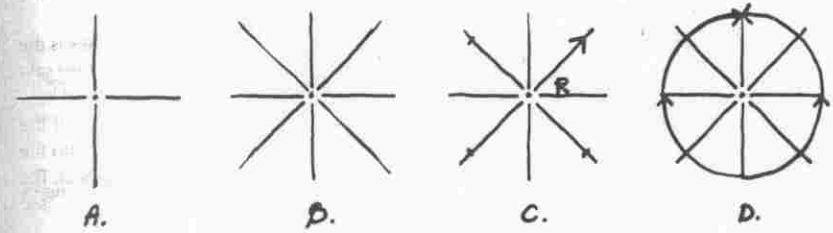
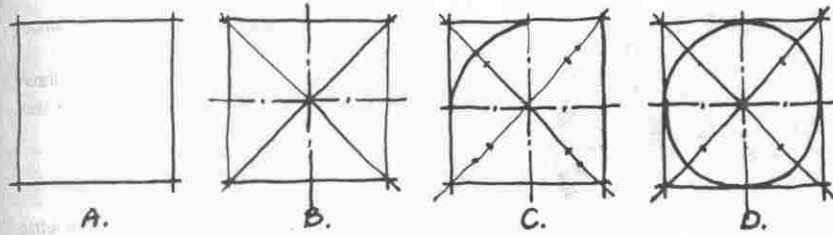

## ELLIPSES

USED FOR CIRCLES IN VIEWS WHERE CIRCLE IS NOT PERPENDICULAR TO THE VIEWER.

DRAW ENCLOSING PARALLELOGRAM.  
FIND TANGENT POINTS.  
LIGHTLY DRAW IN MAJOR & MINOR ARCS.  
COMPLETE AND DARKEN ARCS.

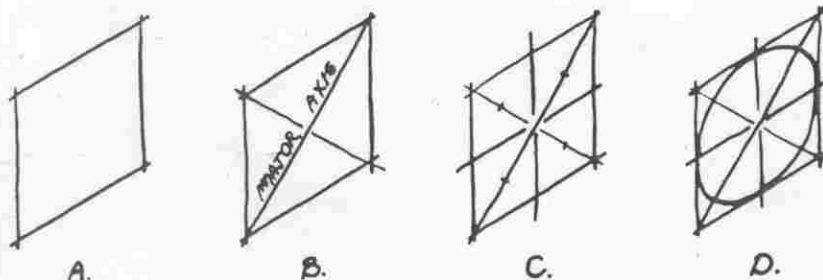
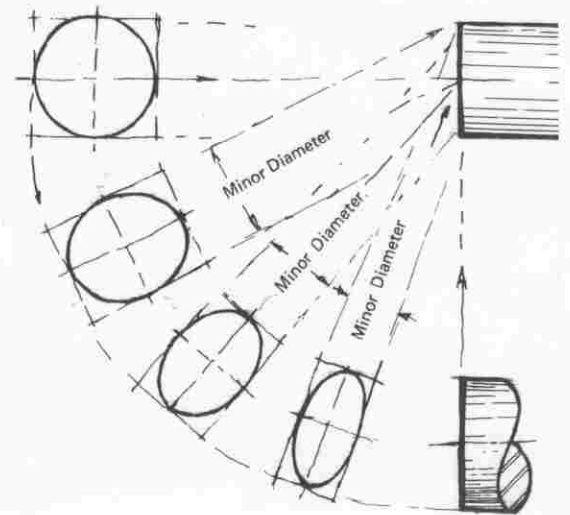
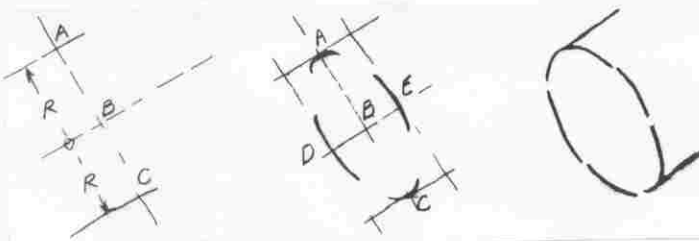

UNIVERSITY OF TOLEDO  
ENGINEERING TECHNOLOGY DEPT.  
CET-1100 ARCHITECT. GRAPHICS

**TECHNICAL  
SKETCHING**

SEMESTER: .....

CLASS HANDOUT: .....

**TS-3**

# SKETCHING OBJECTS

1. STUDY OBJECT UNTIL IT'S UNDERSTOOD.
2. DETERMINE VIEWS REQUIRED TO BEST DESCRIBE OBJECT.
3. BLOCK THE VIEWS LIGHTLY WITH CONSTRUCTION LINES.
4. CHECK MAIN PROPORTIONS.
5. DIM CONSTRUCTION LINES WITH AN ERASER.
6. SKETCH OVER CONSTRUCTION LINES WITH PROPER WEIGHT LINES.
7. ADD DIMENSIONS & NOTES TO DESCRIBE OBJECT.

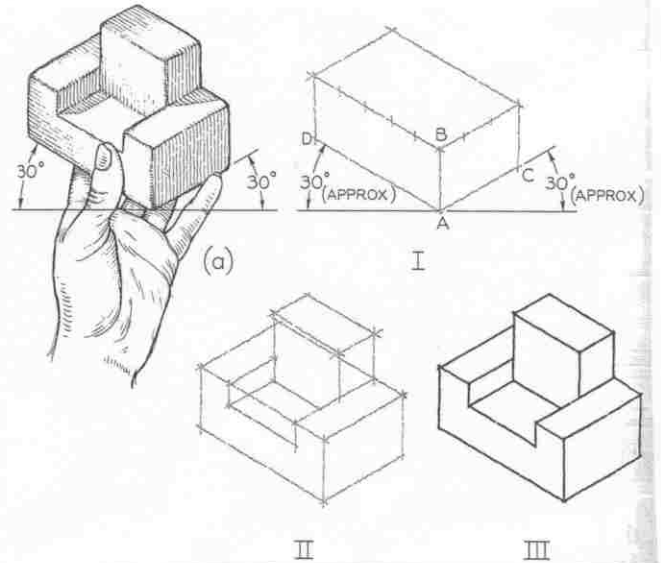
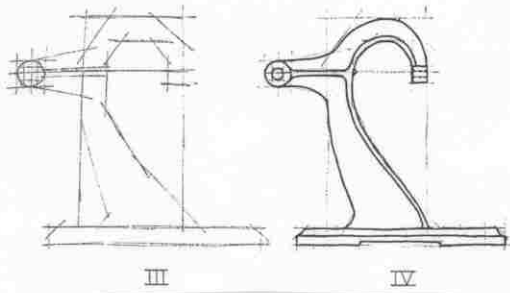
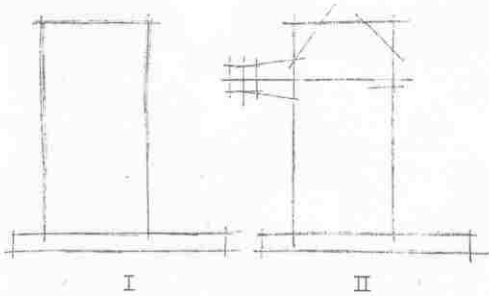
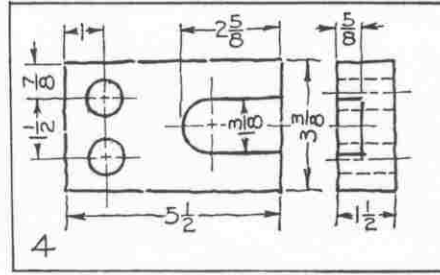
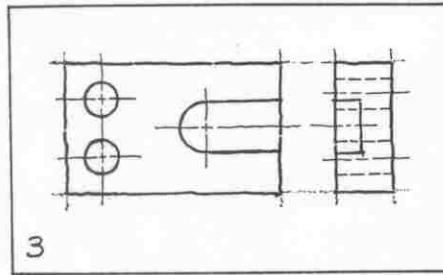
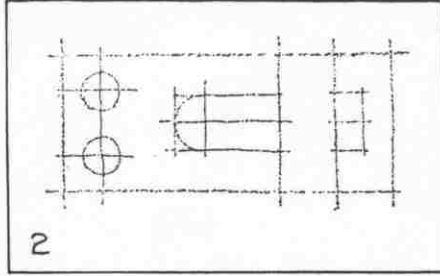
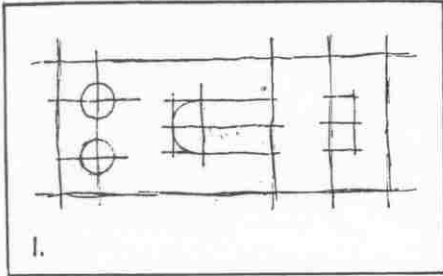

UNIVERSITY OF TOLEDO  
 ENGINEERING TECHNOLOGY DEPT.  
 CET-1100 ARCHITECT. GRAPHICS

## TECHNICAL SKETCHING

SEMESTER: \_\_\_\_\_

CLASS HANDOUT: \_\_\_\_\_

TS-4