

Concrete Pavement Joints

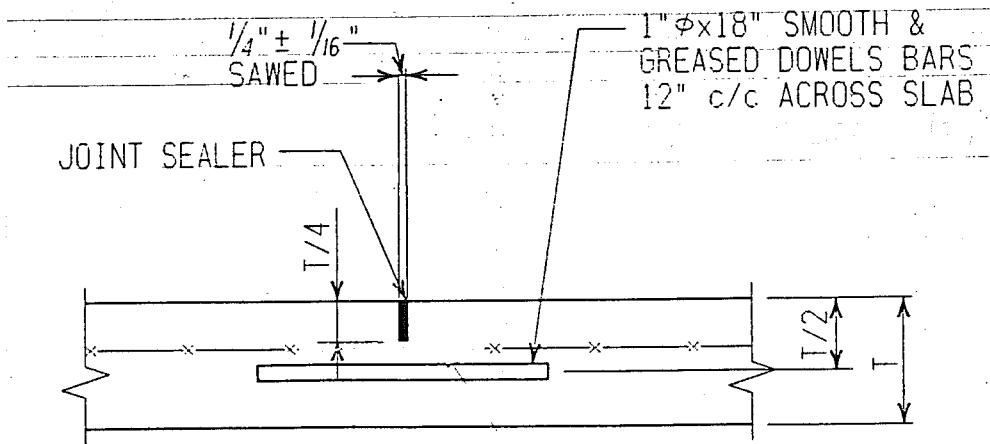

TRANSVERSE CONTRACTION JOINT

NO SCALE

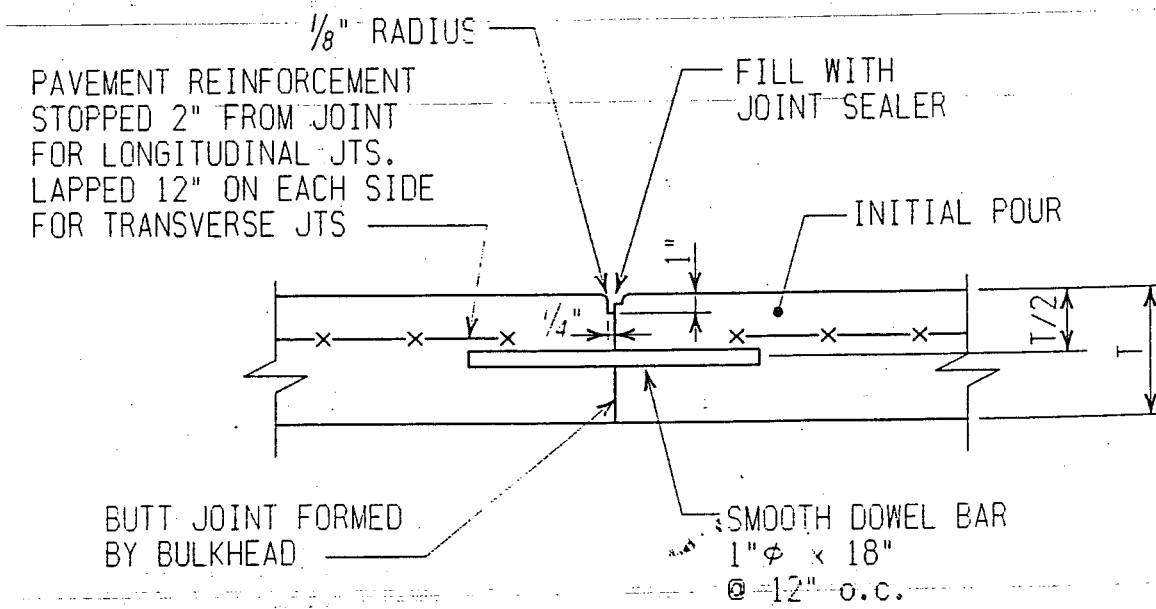

CONSTRUCTION JOINT

NO SCALE:

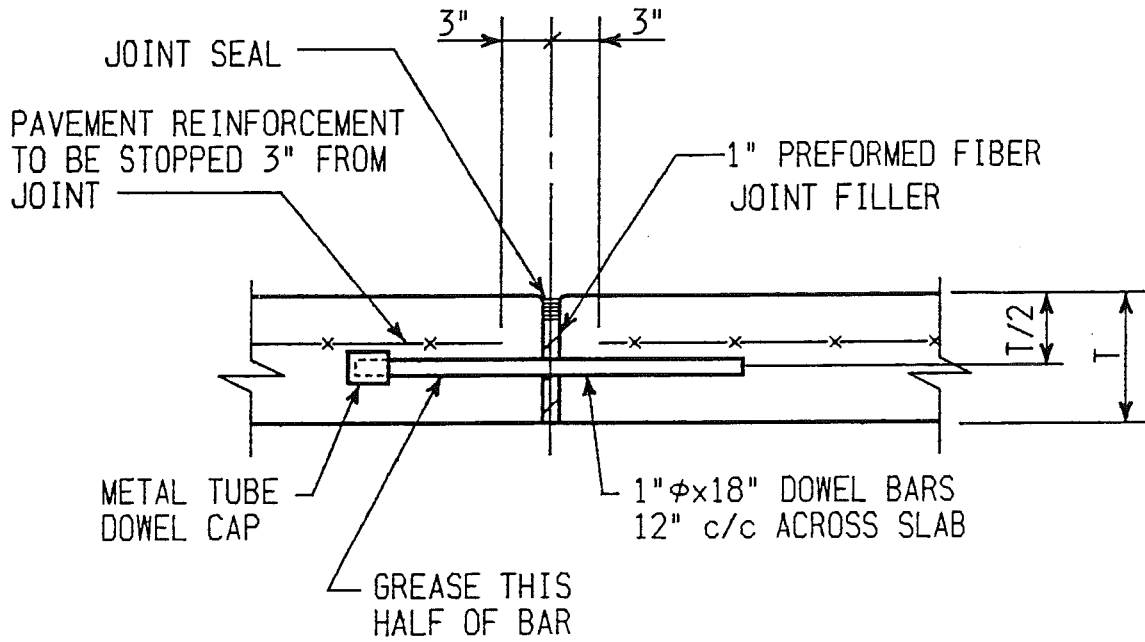

TRANSVERSE EXPANSION JT.

NO SCALE

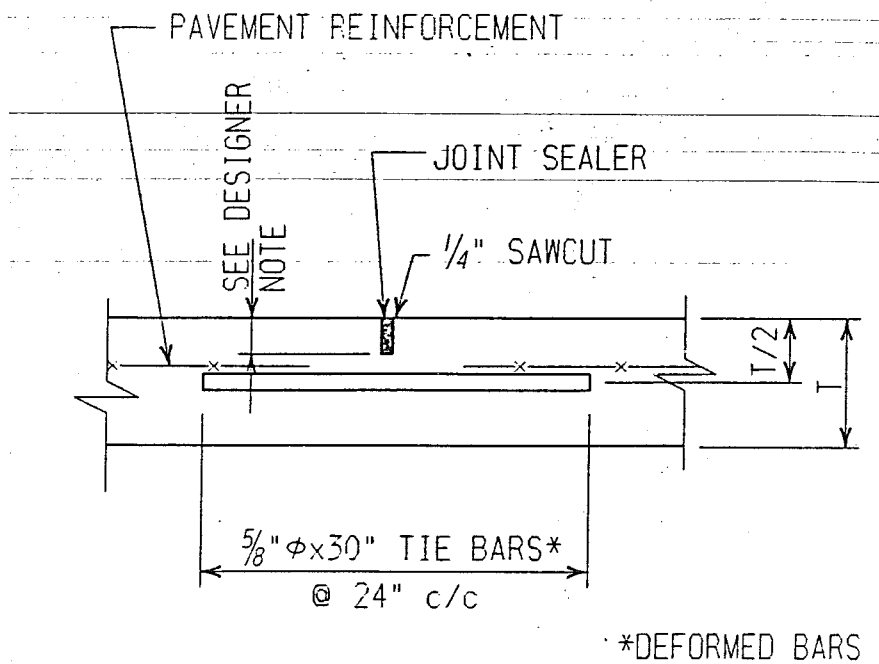

LONGITUDINAL LANE TIE JOINT

NO SCALE

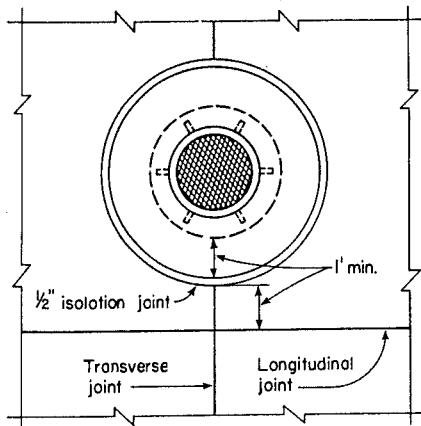
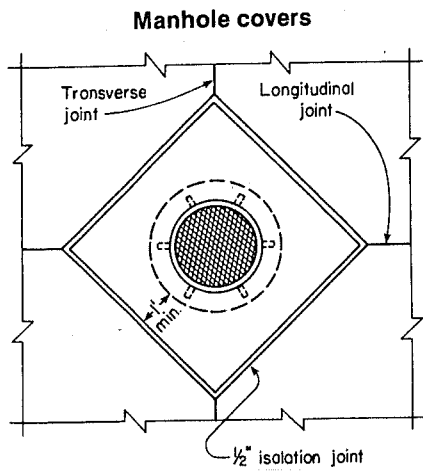

Drainage inlets

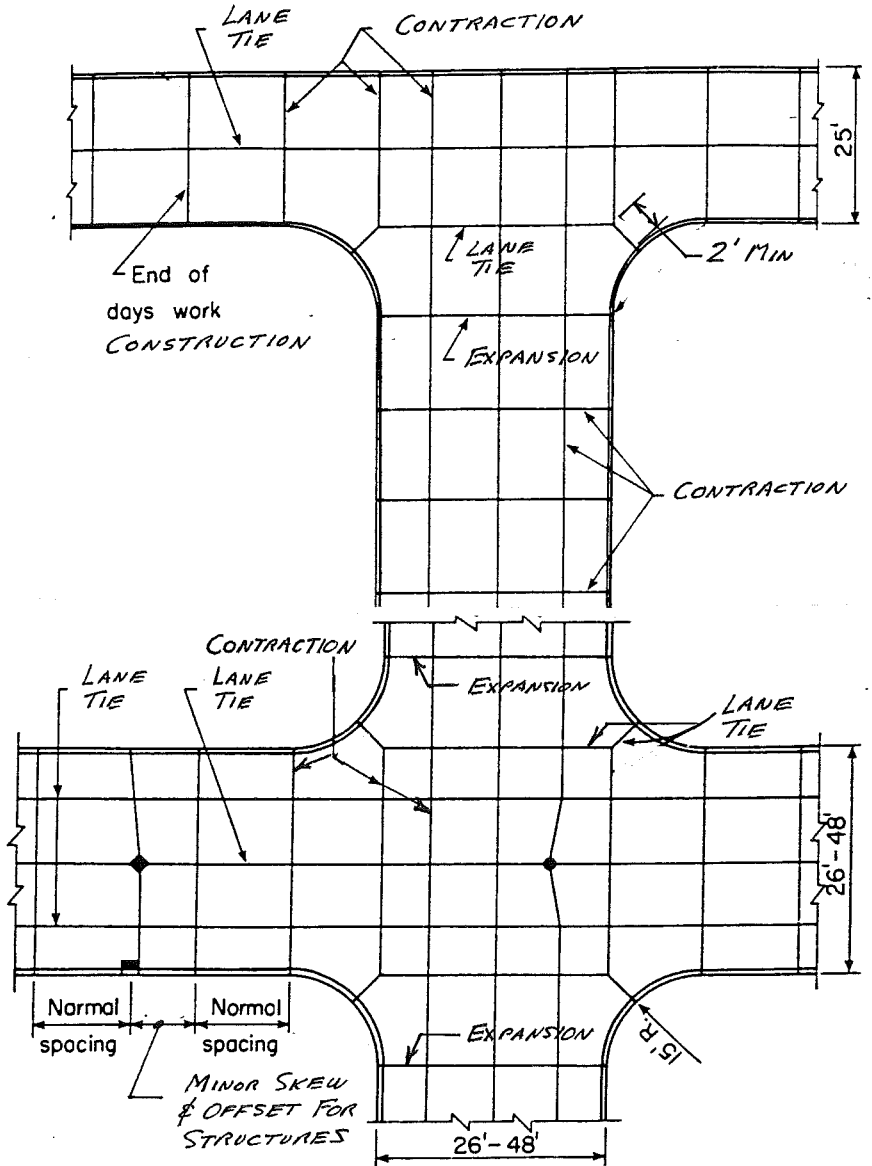
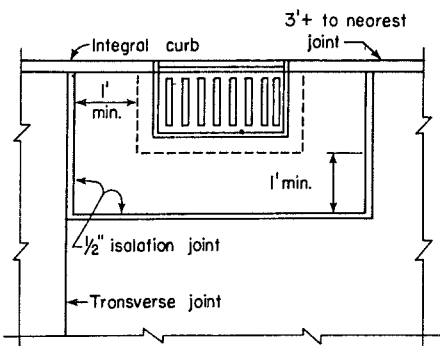

TABLE 4.4 RECOMMENDED DOWEL SIZE AND LENGTH

Slab thickness (in.)	Dowel diameter (in.)	Dowel length (in.)
5	5/8	12
6	3/4	14
7	7/8	14
8	1	14
9	1 1/8	16
10	1 1/4	18
11	1 3/8	18
12	1 1/2	20

Note. All dowels spaced at 12 in. on centers, 1 in. = 25.4 mm.

Source. After PCA (1975).